

PARTS LIST						
ITEM	QTY	PART NO.	PART DESCRIPTION	LENGTH	UNIT WT.	NET WT.
1	1	X-WWM03	3' STAND-OFF ARM / WALL MOUNT		40.14	40.14
2	4	G58LW	5/8" HDG LOCKWASHER		0.03	0.10
3	4	A58FW	5/8" HDG A325 FLATWASHER		0.03	0.14
4	4	A58NUT	5/8" HDG A325 HEX NUT		0.13	0.52
5	4	A582112	5/8" x 2-1/2" HDG A325 HEX BOLT		0.33	1.34
6	2	X-UB1212	1/2" X 2-1/2" X 4-1/2" X 2" GALV. U-BOLT		0.66	1.31
6	2	X-UB1300	1/2" X 3" X 5" X 2" GALV U-BOLT		0.70	1.39
7	4	G12FW	1/2" HDG USS FLATWASHER		0.03	0.14
8	4	G12NUT	1/2" HDG HEAVY 2H HEX NUT		0.07	0.29
9	4	G12LW	1/2" HDG LOCKWASHER		0.01	0.06
					TOTAL WT. #	24.89

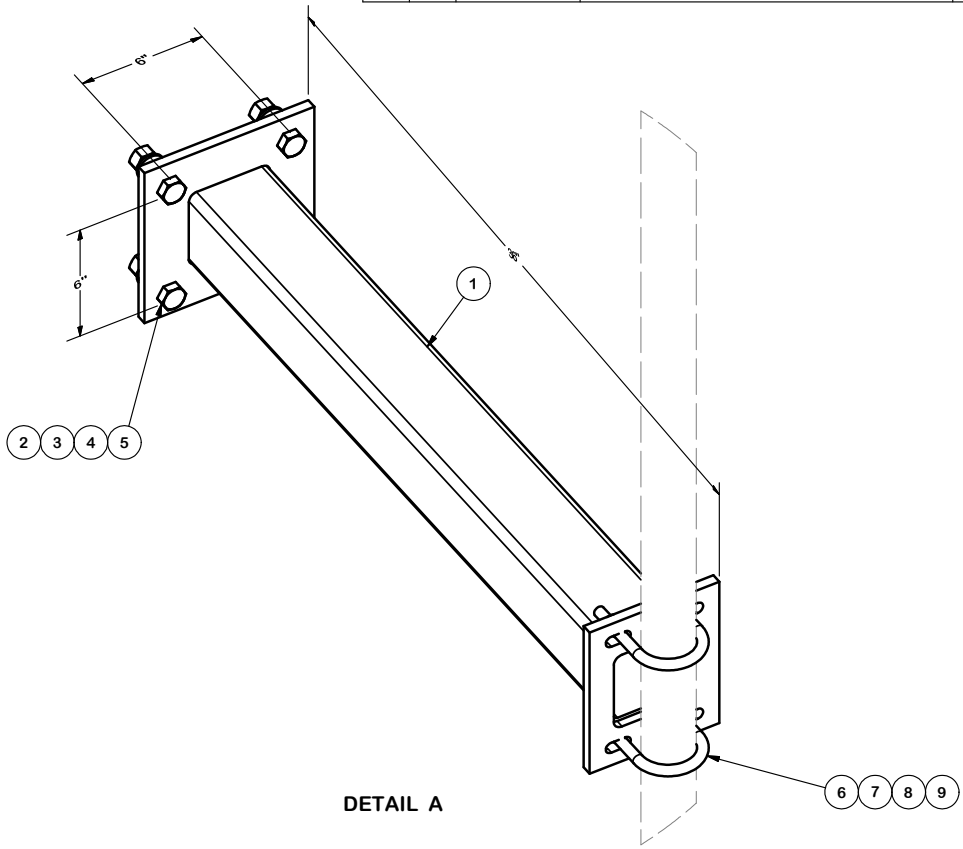

DETAIL A

**TOLERANCE NOTES**  
 TOLERANCES ON DIMENSIONS, UNLESS OTHERWISE NOTED ARE:  
 SAWED, SHEARED AND GAS CUT EDGES ( $\pm 0.030"$ )  
 DRILLED AND GAS CUT HOLES ( $\pm 0.030"$ ) - NO CONING OF HOLES  
 LASER CUT EDGES AND HOLES ( $\pm 0.010"$ ) - NO CONING OF HOLES  
 BENDS ARE  $\pm 1/2$  DEGREE  
 ALL OTHER MACHINING ( $\pm 0.030"$ )  
 ALL OTHER ASSEMBLY ( $\pm 0.060"$ )

PROPRIETARY NOTE:  
 THE DATA AND TECHNIQUES CONTAINED IN THIS DRAWING ARE PROPRIETARY INFORMATION OF VALMONT INDUSTRIES AND CONSIDERED A TRADE SECRET. ANY USE OR DISCLOSURE WITHOUT THE CONSENT OF VALMONT INDUSTRIES IS STRICTLY PROHIBITED.

DESCRIPTION 3' STAND-OFF WIRELESS WALL MOUNT, SITE PRO 1		
CPD NO. 4714	DRAWN BY LMD 12/17/2012	ENG. APPROVAL
CLASS 81	SUB 01	DRAWING USAGE CUSTOMER
		CHECKED BY BMC 12/17/2012

 A valmont COMPANY	Locations: New York, NY Atlanta, GA Los Angeles, CA Plymouth, IN Salem, OR Dallas, TX
	Engineering Support Team: 1-888-753-7446
PART NO. WWM03	DWG. NO. WWM03